

Bidons cylindriques dessus plat ou chapiteau Cylindrical cans with flat or dome top

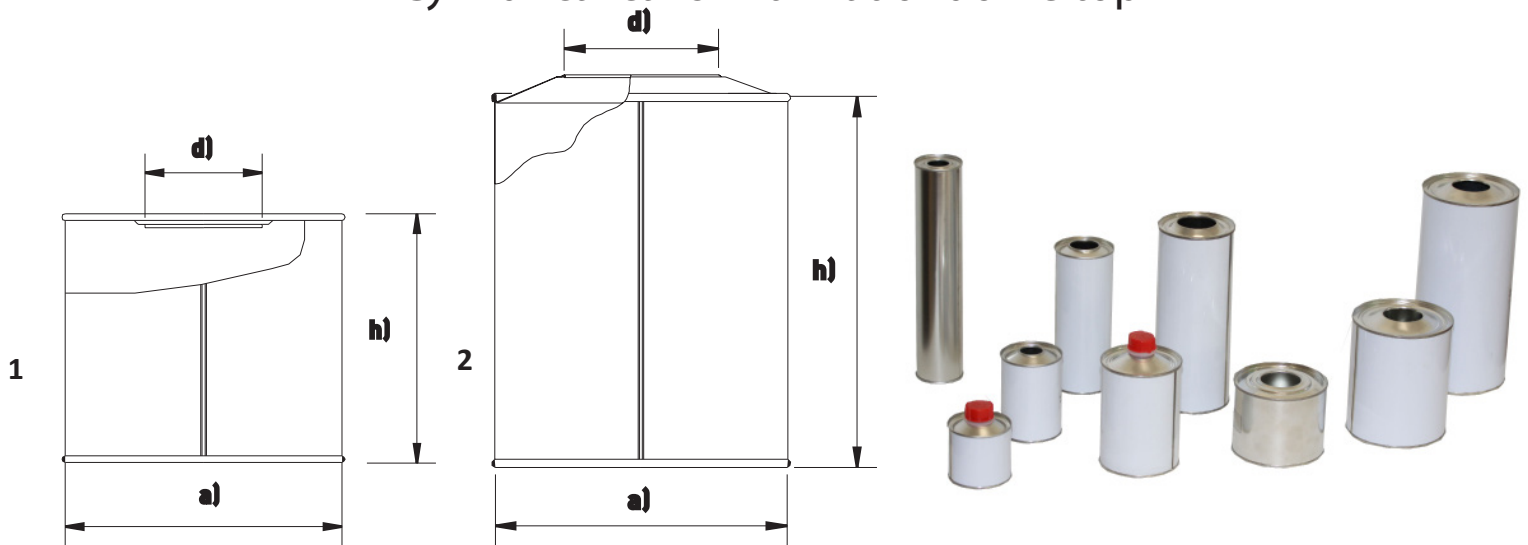

Format Size	Volume commercial (l) Trade volume	Volume ras-bord (l) Brimful volume	Diamètre (mm) a) Diameter	Hauteur (mm) h) Height	Dessus plat (1) / chapiteau (2) Flat (1) / Dome top (2)	Fermeture d) Closure	Quantité par palette (800x1200mm) Quantity per pallet	UN / RID ADR	Remarques Remarks
D 52 x 105	0.15	0.2	52	105	1	24 DIN	3 280	N / N	
D 52 x 135	0.25	0.28	52	135	1	24 DIN	2 624	N / N	
D 52 x 255	0.5	0.53	52	255	1	24 DIN	1 318	N / N	
D 65 x 100	0.25	0.33	65	100	1 / 2	24 DIN/32 REL	2 210	N / N	2)
D 65 x 171	0.5	0.56	65	171	1 / 2	24 DIN/32 REL	1 326	N / N	2)
D 73 x 138	0.335	0.57	73	138	1	24 DIN	1 440	N / N	2)
D 83 x 118	0.5	0.63	83	118	1 / 2	24/32/42 DIN	1 296	Y / Y	2)
D 83 x 209	1	1.13	83	209	1 / 2	24/32/42 DIN	720	Y / Y	2)
D 83 x 220	1	1.18	83	220	1 / 2	24/32/42 DIN	720	Y / Y	2)
D 99 x 90	0.5	0.69	99	90	1 / 2	24/32/42 DIN	1 188	N / N	2)
D 99 x 149	1	1.14	99	149	1 / 2	24/32/42 DIN	693	N / N	2)
D 109 x 80	0.5	0.74	109	80	1 / 2	1)	1 120	N / N	2)
D 109 x 132	1	1.23	109	132	1 / 2	1)	640	N / N	2)
D 109 x 217	2	2.02	109	217	1 / 2	1)	400	N / N	2)

1) 24 / 32 / 42 / 57 DIN dessus plat ; 42 DIN dessus chapiteau

2) Indice tactile de danger embossé sur demande.

24 / 32 / 42 / 57 DIN on flat top; 42 DIN on dome top

Tactile warning emboss possible.