

High performance tinplate aerosol cans



Quality and performance to protect your products and promote your brand

In our 4 European factories, we manufacture steel aerosols for the cosmetics, household, food industry, industrial and chemical industry markets. We cover the entire European and North African market and also supply components worldwide.

For more than 30 years, our products comply with the higher standards of quality and safety. Thanks to our strategy of sustained investment in R&D and equipment, we have built state-of-the-art facilities equipped with leading European manufacturers machineries. In combination with the great experience of our team, this enables us to ensure dimensional accuracy and pressure safety with a big production output.

Expertise and a strong service-oriented approach are the main assets that our team puts at your disposal.

Our aerosol cans come in various diameters and specifications and are fully customizable.

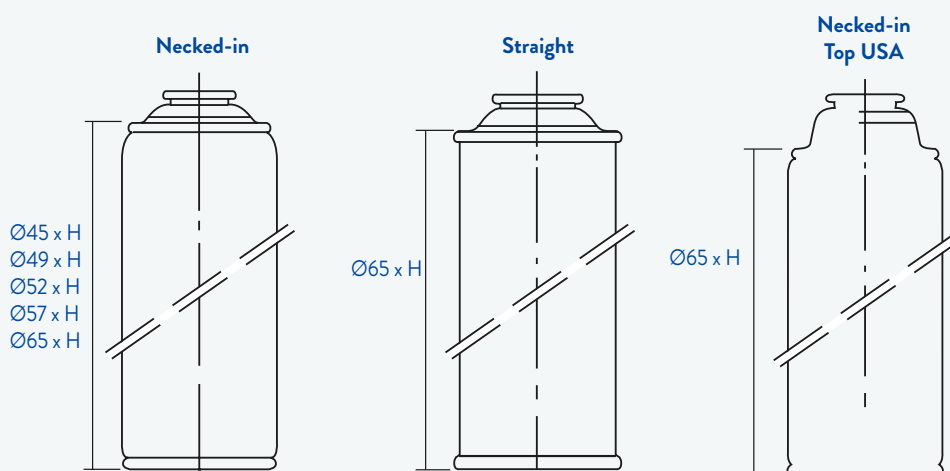

Brimful Capacity (ml.)	Filling Volume (ml.)	Oz	Height diameter (in mm)					
			Ø 45/41	Ø 49/45	Ø 52/48	Ø 57/52	Ø 65	Ø 65/60
140	100	4	96					
175	125	5	118					
210	150	6	140	119	105			
270	200	8	178	151	132	100		
335	250	10		185	161	136	104	104
405	300	12		222	195	164	122	122
520	400	16			244	207	157	157
650	500	20				257	195	195
800	600	24					240	240
1000	750	30					300	300

Contact us, and we will accompany you to find the product that fits your specific needs

Service and expertise to guarantee efficiency and peace of mind

Our technical and industrial teams provide a pool of expertise and services to support you in defining your packaging project and ensuring perfect compatibility between our packaging and your products and processes, the guarantee of our shared success:

Quality processes

We adopt best-in-class methods for testing our aerosol cans and providing you with the most secure and efficient packaging:

- In-line high pressure leak testing
- Water bath for micro leaking detection
- Regular dimensional accuracy
- Seam control by high definition camera and automatic pattern detection
- Destroying tests to detect the deformation and burst pressure

All these arrangements secure the constant good quality of our Aerosol cans abiding by the FEA standards.



Metal printing and embossing

In our printing centres, we strive to faithfully transpose in metal, the most beautiful expression of your brand. The printing is done on a 4 to 6-colour-press (UV-offset). We can also emboss your aerosol can whether it is to highlight security information such as Safety Triangle or to promote a detail of your design. Contact us to create your design.

Customer technical support

Our international team of experienced engineers and technicians are at your disposal to assist you in using our aerosols. They are experts in packaging and processes and are available to be on site with your team.

Food contact Assistance

Our quality, industrial and laboratory teams provide expertise and assistance in understanding and complying with the requirements of International regulations concerning food contact. We support you with pack tests to ensure our aerosol can is the best match for your content. We use a BPA-NI varnish for the food market aerosol cans.



Tinplate aerosols, the recycling champions

Reliable, strong, allowing preservation without additives, long shelf life without the extra expense of energy for refrigeration and of course 100 % recyclable, the advantages of metal packaging are many and allow you to meet the challenges of today:

- In Europe, 80% of metal packaging is recycled, making it the most recycled packaging
- Metal is a permanent material which can be recycled infinitely without losing its inherent qualities
- Steel for packaging always contains recycled steel

WE CAN PRINT THE METAL RECYCLE FOREVER LOGO ON YOUR AEROSOL CAN. JUST ASK OUR TEAM

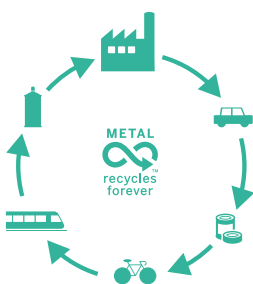

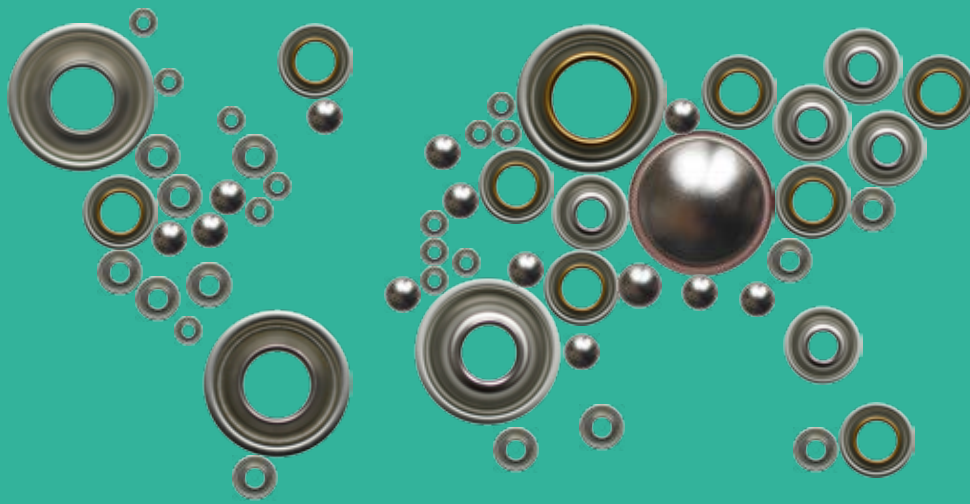

Our 4 factories located in Spain, Germany, Wales and Russia can offer our customers a local service on the main European markets. We also deliver components worldwide.



Stiftstrasse 2
65549 Limburg an der Lahn
GERMANY
T. +49 6431 299 303
info@aerosol-limburg.de



Grupo Metalgrafico, S.A.
Carretera de Logrono Km 16 - Pol. industrial, s/n
50629 Sobradiel (Zaragoza)
SPAIN
T. +34 976 77 02 77
export@grumetal.es



Unit 2 Hendy Industrial Estate,
Hendy - Pontarddulais
SA4 0XP
Swansea-WALES
T. +44 17 92 882 766
aerosolorders@massilly.com



22 Ulitsa Montazhanya
City of Nevinnomyssk Stavroplsky Kray
357100 Nevinnomyssk -
RUSSIA
T. +7 (86554) 96141
oolinar@oolinar.ru - www.oolinar.ru



Metal Lover since 1911

Our reliability and strong service-oriented approach makes us a leader in manufacturing of metal packaging: **closures, food cans, aerosol cans, industrial packaging, and decorated tin boxes.**

We believe in the beneficial qualities of metal, in its ability to protect our clients' products as well as the planet. And because our packaging contain products which the consumers put on their plate and on that of their children, we maintain the highest standards of quality and safety.

The Massilly Group is located in 15 countries via its 25 subsidiaries.

www.massilly.com